

Stilus Moldes

COMO PREGAR ZÍPER INVISÍVEL

Para aplicar o zíper invisível só é possível com a utilização de um calcador especial, esse procedimento é diferente das demais porque os dentes ficam totalmente ocultos e só o curso pode ser visto. É preciso aplicá-lo antes de fazer a costura.

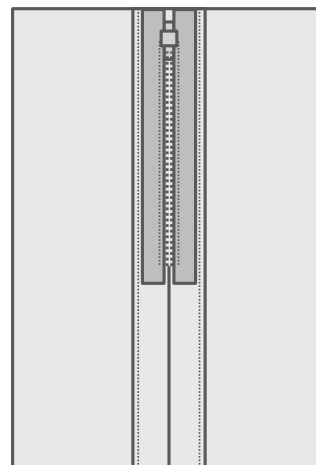
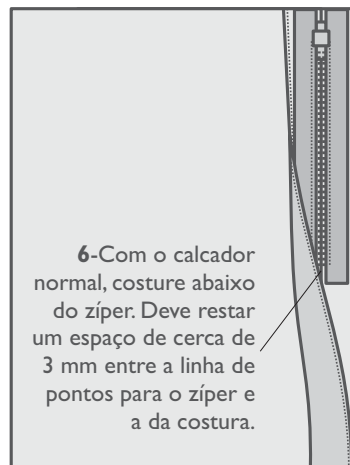
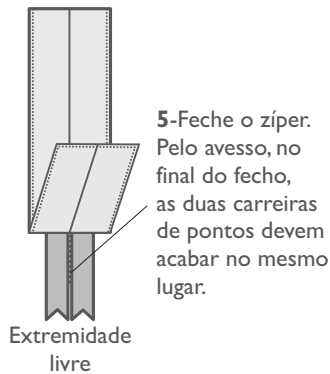
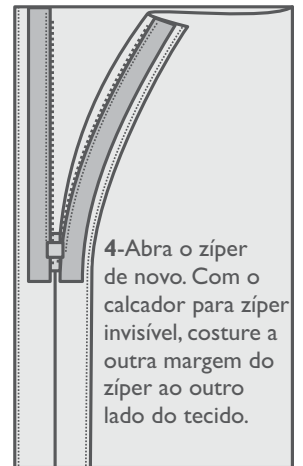
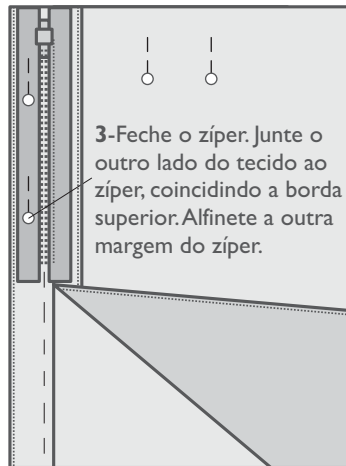
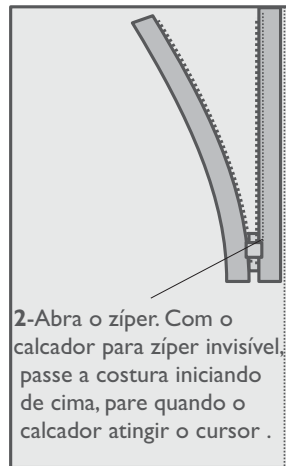
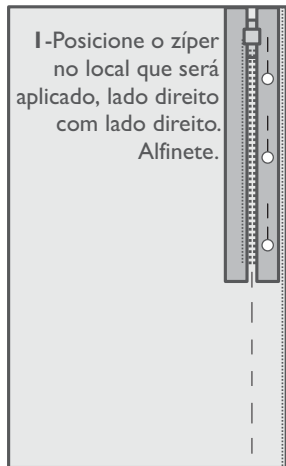

7-Costure os últimos 3 cm da margem do zíper à margem de costura, para deixar o fecho bem preso.

